

LEGEND

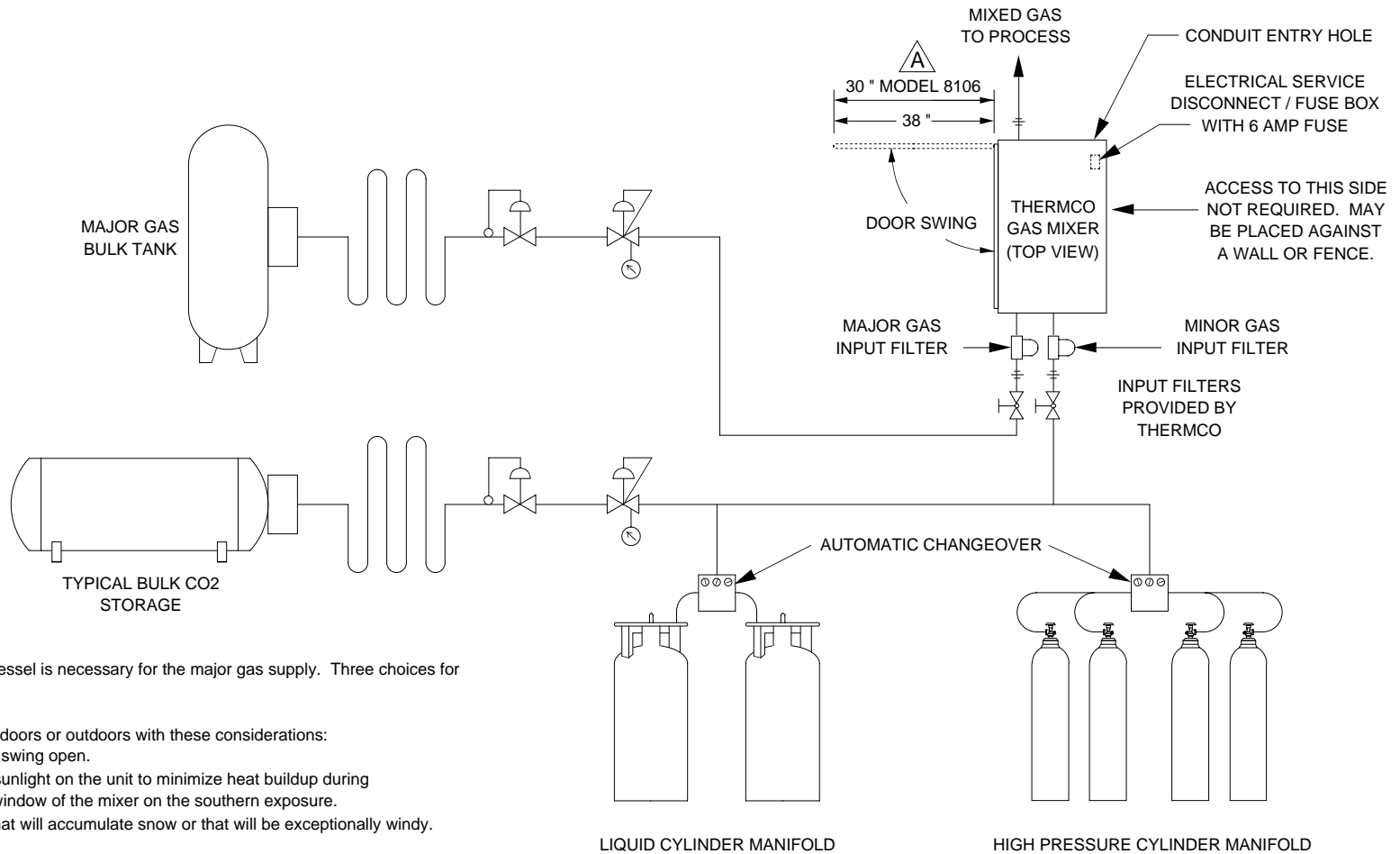
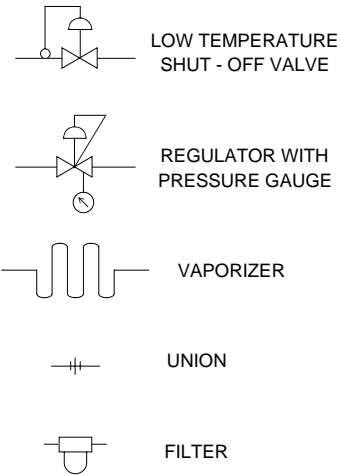

NOTES:

GAS SUPPLY: Normally a bulk storage vessel is necessary for the major gas supply. Three choices for the minor gas supply are shown.

- SITING:** The gas mixer may be located indoors or outdoors with these considerations:
1. Allow clearance for the front door to swing open.
 2. If possible, avoid areas with direct sunlight on the unit to minimize heat buildup during the summer. Do not face the front window of the mixer on the southern exposure.
 3. In cold environments, avoid areas that will accumulate snow or that will be exceptionally windy.

PIPING: Piping should be chosen with consideration for the pressure and chemical nature of the gas, sized large enough to deliver the proper pressure to the gas mixer under flowing conditions. See Recommended Pipeline Sizes in the gas mixer instructions.

POWER REQUIREMENTS: Gas mixers made for installation in the U.S. and Canada will require 115 VAC (± 10 VAC), 60 Hz, 1 ϕ . For gas mixers for other locations, see instruction manual for power requirements.

GAS TEMPERATURE: The two supply gases should enter the gas mixer at nearly equal temperatures to achieve the proper mixing accuracy. If the gas supplies will be at significantly differing temperatures, the resultant mixing inaccuracy should be considered and the proper corrective action taken. Design to prevent exposure of the gas mixer to high pressures or liquid gases should be practiced.

SIGNAL WIRING: Electrical signals (4 - 20 mA, 0 - 100 mV, etc.) run remotely from the analyzer enclosure must be run in a separate conduit or shielded cable.

H					SCALE: N.T.S.	B. M. NUMBER:	DRAWN BY: DB
G					DATE: 8-10-93	CUSTOMER:	APPROVED BY:
F					S. O. NUMBER:		SUPERSEDES: 2-9812
E					TITLE: RECOMMENDED INSTALLATION OF OUTDOOR GAS MIXERS		
D					DRAWING NUMBER: 1-10679		
C							
B							
A	ADDED MODEL 8106 INFO	DMR	7-12-02				
	REVISIONS	BY	DATE				

MATERIAL:

FINISH: