

LEGEND

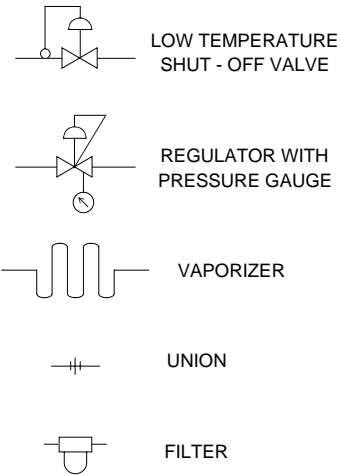

OUTDOORS

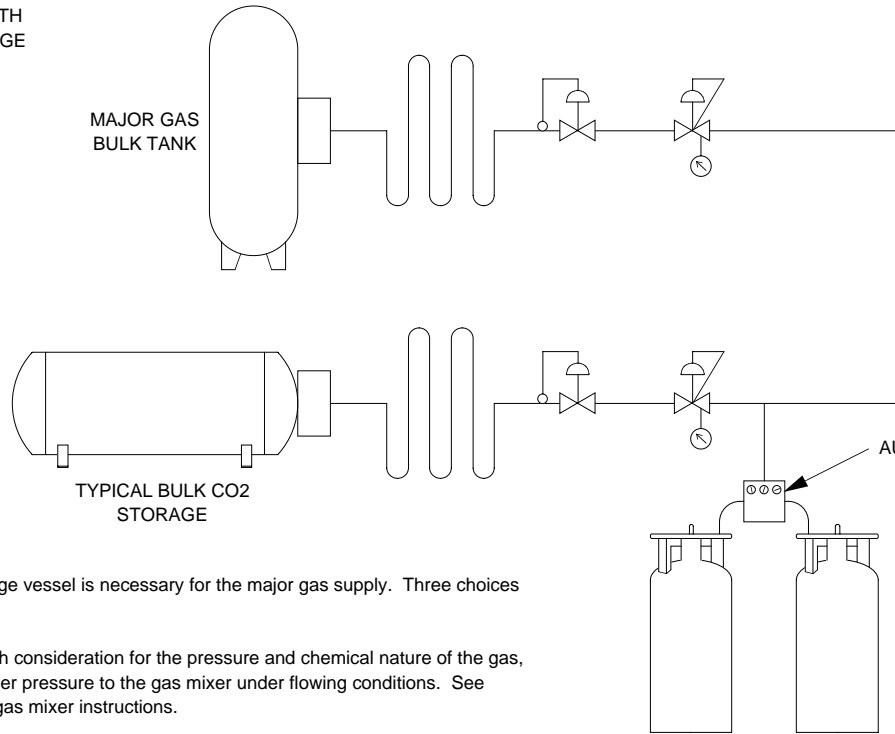

INDOORS

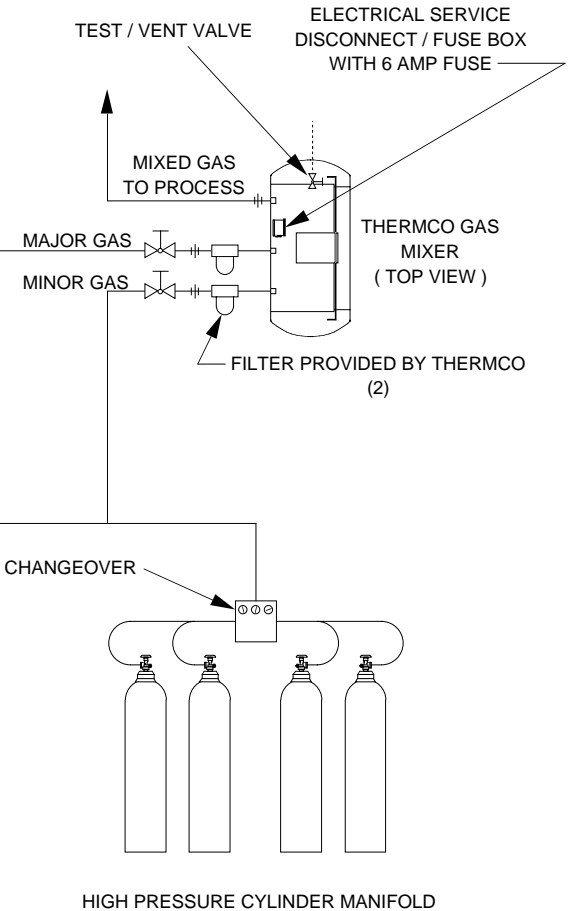

NOTES:

GAS SUPPLY: Normally a bulk storage vessel is necessary for the major gas supply. Three choices for the minor gas supply are shown.

PIPING: Piping should be chosen with consideration for the pressure and chemical nature of the gas, sized large enough to deliver the proper pressure to the gas mixer under flowing conditions. See *Recommended Pipeline Sizes* in the gas mixer instructions.

CLEARANCE: Leave at least 1 - 1/2 feet clearance to both sides, and 2 feet to front and rear of mixer.

POWER REQUIREMENTS: Gas mixers made for installation in the U.S. and Canada will require 115 VAC (± 10 VAC), 60 Hz, 1 ∅. For gas mixers for other locations, see instruction manual for power requirements.

GAS TEMPERATURE: The two supply gases should enter the gas mixer at nearly equal temperatures to achieve the proper mixing accuracy. If the gas supplies will be at significantly differing temperatures, the resultant mixing inaccuracy should be considered and the proper corrective action taken. Design to prevent exposure of the gas mixer to high pressures or liquid gases should be practiced.

WIRING: Electrical signals (4 - 20 mA, 0 - 100 mV, etc.) run remotely from the analyzer enclosure must be run in a conduit separate from the power wiring (115 VAC, remote Horn wiring), or in special shielded cable to eliminate the effects of electrical interference with the instrument signal.

H			
G			
F			
E			
D			
C			
B			
A			
REVISIONS		BY	DATE

THERMCO			INSTRUMENT CORPORATION
SCALE: N.T.S.	B. M. NUMBER:	DRAWN BY: DB	
DATE: 6-18-93	CUSTOMER:	APPROVED BY:	
S. O. NUMBER:	SUPERSEDES: 2-9342		
TITLE: RECOMMENDED INSTALLATION OF NON-FLAMMABLE INDOOR GAS MIXER			DRAWING NUMBER: 1-10654

MATERIAL:

FINISH: